

# Module Assessment, Part 1

STUDENT RESOURCE **A.1**  
ASSESSMENT PART 1**1**

solid

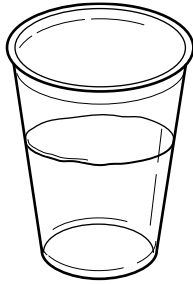

liquid

**2**

sink

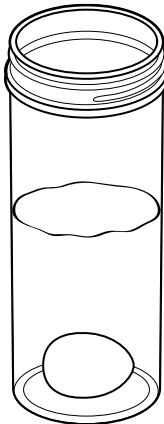

float

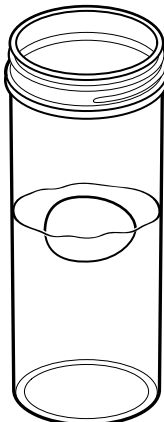

**Directions: 1–2.** Have students draw a line from the word to the correct picture.

# Module Assessment, Part 2

**3** What would make ice melt faster?

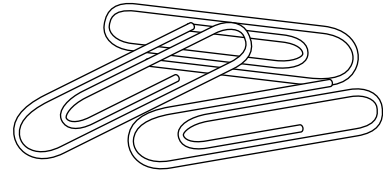
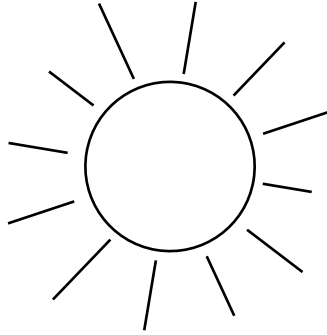
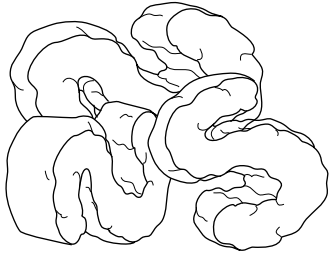

**4** What would make ice melt slower?

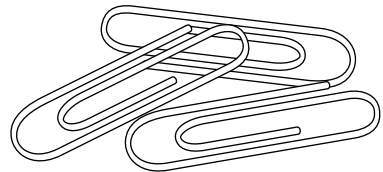
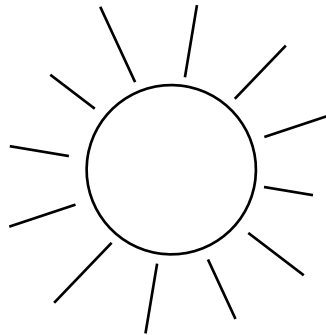
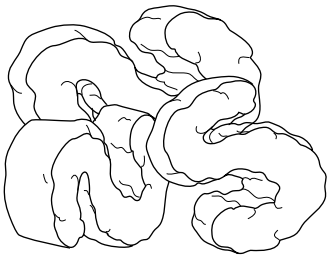

**Directions: 3–4.** Have students circle the correct picture to answer the question.

# Module Assessment, Part 3

STUDENT RESOURCE **A.3**

ASSESSMENT PART 3



## Materials:

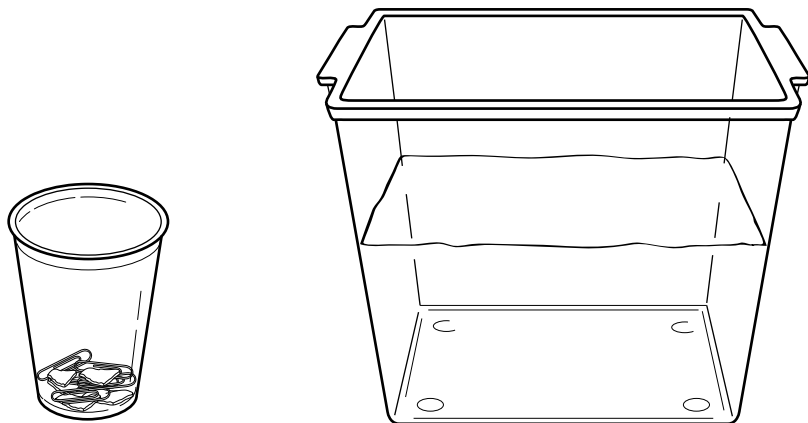

### 5 Can you separate the mixture?

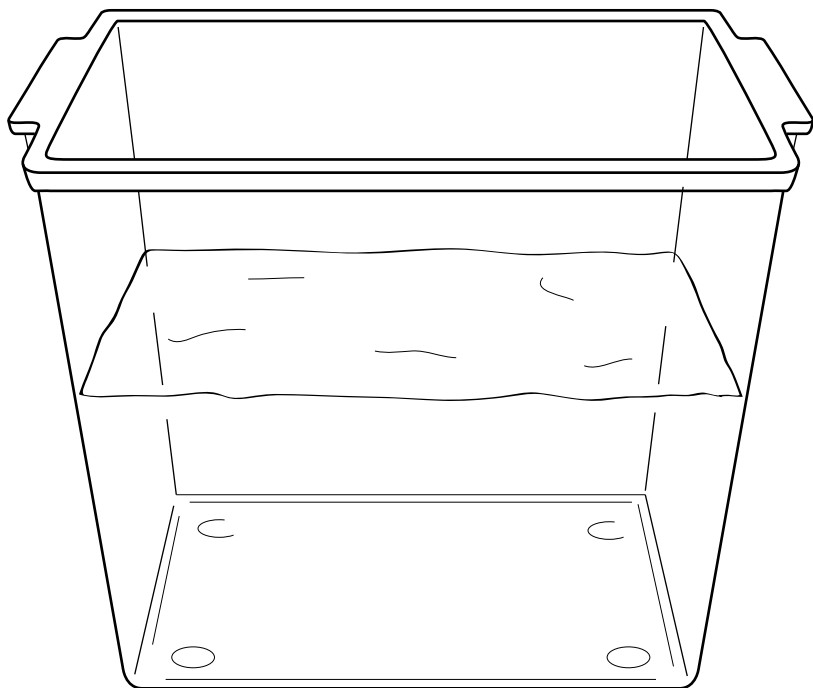

**Directions: 5.** Have students draw where the objects in the mixture ended up after they put them in the container of water.